

WELLCAM

微政工業股份有限公司
WELLCAM MACHINERY CORP.

42953 台灣台中市神岡區新庄里和陸路一段 741 號
No.741, Her Moh Road, Sec. 1, Seng Kung Dist,
Taichung City 42953 Taiwan
TEL:886-4-25624171
FAX:886-4-25621762
E-mail:wellcam@wellcam.com.tw
http://www.wellcam.com.tw



● 經銷商 \ Distributor

● 微政工業股份有限公司版權所有 WC-20121022

● 本公司隨時進行研發修改產品，因此本型錄內容規格得以變更、恕不另行通知。
● Specifications, dimensions, design characteristics are subject to change without previous notice.



微 政 攻 牙 機
WELLCAM
TAPPING MACHINE





BRIEF INTRODUCTION

Wellcam Machinery Corp., established in 1989, and was starting her business in making varied industrial machines, special purpose machines and sell to the countries in Southeast Asia. The parts used on the machines we developed are as high as 80% to be in-house production.

In 1998, we were concentrating in the R&D, manufacture, distribution of tapping machines under the brand name "Wellcam". At the same time we use the tapping machine we made in our other production line as trial and the reference for the machine modification. The machines have obtained good reputation by all our customers overseas who is selling Wellcam Tapping Machines comes from Russia, France, Belgium, Ukraine, Italy, Turkey, India, Indonesia, Malaysia, Korea, China and domestic market. Based on the ever-lasting policy, keep improving in product quality, technique and service, so as to meet customer's satisfaction has been always our commitment.

PRODUCT LINE

WELLCAM Tapping Machine is good for many kinds of industry. Such as in support of CNC machine center by processing the tapping works left by CNC. Or in support of CNC laser machine to finish the tapping work.

The application of the tapping machine is covering wide range of industry. For example, sheet metal, control panel, valves, pneumatic valves, hydraulic valves, dies, metal parts. Believing our tapping machine can significantly decrease the production cost, increase the production efficiency. It plays a very important role in the field of machine processing nowadays and is an indispensable equipment in your factory.

PATENTS AND CERTIFICATES

產品專利，產品認證



公司簡介

本公司成立於1989年，公司早期所生產製造的產品起始於各種型式產業機械及專用機械之生產製造，並將產品銷售至東南亞各國，本公司開發製造的產品，其機器零件自製率高達80%。

本公司於1998年致力於規劃新一代產品 TAPPING MACHINE 的開發、設計、製造與銷售，並同時將所開發產品第一時間投入於本公司加工生產線加以試練，以實際的使用經驗及測試數據加以改良 WELLCAM 產品，在市場開發目標方面，規劃將 WELLCAM 產品推向全世界各國，目前 WELLCAM 品牌產品在世界各國，包含俄羅斯、法國、比利時、烏克蘭、義大利、土耳其、印度、印尼、馬來西亞、韓國、中國及台灣本國都獲得許多肯定與好評，本公司將秉持客戶的支持與肯定，也得以永續經營的理念，努力追求技術與品質的提昇，以獲得客戶更進一層的信任，為提供顧客更質優服務為使命。

產品介紹

WELLCAM Tapping Machine 可使用於各種產業，可配合 CNC 機械加工未完成的攻牙作業，減少 CNC 機械攻牙作業所浪費的時間，增加 CNC 機械的工作效率，配合 CNC 雷射切割機完成攻牙作業，其產品應用的產業範圍非常廣泛，例如板金類、電氣箱製造、閥類、氣壓閥、油壓閥、水閥、模具類及金屬零件製造加工業。

相信我們所提供的攻牙機械將能為客戶降低生產成本，提升工作效能，成為現代加工作業不可缺少的設備。



GT-Series

GT-Series Air Tapping Machine

GT 系列氣壓攻牙機

Numbering system for GT-Series

1. GT - stands for series of Wellcam pneumatic tapping machines
2. GT -10,12,16,20,24 stands for tapping capacity & RPM specification.
3. " V " (Vertical) stands for vertical tapping, " H " (Horizontal) stands for horizontal tapping.
4. " L, M, S " stands for the size of tapping arm (working area)

Features for GT-Series

1. GT-Series Easier operation, quick positioning, larger working area good for both vertical and horizontal tapping
2. GT-10 Series Suitable for using in the industries of metal sheeting, laser cutting, stamping, aluminum casting, electrical control panel, metal parts...,etc. Increase the production efficiency and production capacity.
3. GT-12 Series Suitable for tapping work pieces made of FC, FCD casting, mild steel, medium-carbon steel, bigger size pieces, linear guide, this series is the most popular tapping machines used in different application.
4. GT-16 Series Using TC-312 #1 tap collets, the tapping machine with the largest torque in our products. It can successfully proceed M16 tapping which can be done by other machines found in the market only by changing up to TC-820 #2 TAP Collets M20.
5. GT-20 & GT-24 Used the tapping specification of M16, M20, M24, PT 3/8, PT 1/2 and suitable for larger work piece, smaller production lot. Good for both vertical & horizontal tapping.

GT-Series 產品編號方式說明

1. 「GT」屬於WELLCAM 產品氣壓系列攻牙機代表編號。
2. 「GT-10,12,16,20,24」, 代表每一款型號氣壓馬達攻牙能力及 RPM 規格之選擇編號。
3. 「V」(Vertical) 表示垂直攻牙作業產品代碼, 「H」(Horizontal) 表示水平側向攻牙作業產品代碼。
4. 「L、M、S」代表產品工作範圍之代碼, 代表攻牙手臂的長短尺寸。

GT-Series 產品特性介紹

1. GT 系列產品操作簡易化輕便, 定位快速, 工作範圍大, 垂直及水平任何角度都能攻牙作業。
2. GT-10 系列適合於機械板金、雷射切割、衝床板金、鋁合金壓鑄工件、電器箱、金屬零件高速攻牙作業, 提高生產效率, 增加產能。
3. GT-12 系列適合於 FC、FCD 鑄件、低碳鋼、中碳鋼材料加工、各種大型工件及線性滑軌等, 此規格是市場上使用最廣泛的機種。
4. GT-16 系列是使用 TC - 312 #1 TAP Collets 規格中扭力最大的產品, 用此規格即可完成 M16 攻牙作業, 一般市面上產品皆需改用 TC - 820 #2 TAP Collets M20 產品規格才能完成 M16 攻牙作業。
5. GT-20 及 GT-24 系列是使用於 M16、M20、M24、PT 3/8、PT 1/2 規格, 適合於較大型物件、大攻牙尺寸、垂直、水平及少量多樣的攻牙作業。

GT-Series



Vertical Air Tapping Machine 立式氣壓攻牙機

GT-10VL | GT-12VL | GT-16VL

Model	型號	GT-10VL	GT-12VL	GT-16VL
Tapping capacity	攻牙能力	M3 - M10	M3 - M14	M3 - M16
Speed RPM	主軸轉速	700 rpm	400 rpm	300 rpm
Work Range	工作範圍	300 m/m - 2000 m/m		
Tapping fixtures	攻牙夾具	TC312 - #1		
Air pressure	空壓壓力	6 kg - 8 kg		
Package Size	包裝尺寸	900 m/m x 500 m/m x 200 m/m		
Net Weight	淨重	26 kg		



Universal Air Tapping Machine 萬向氣壓攻牙機

GT-10HL | GT-12HL | GT-16HL

Model	型號	GT-10HL	GT-12HL	GT-16HL
Tapping capacity	攻牙能力	M3 - M10	M3 - M14	M3 - M16
Speed RPM	主軸轉速	700 rpm	400 rpm	300 rpm
Work Range	工作範圍	300 m/m - 2000 m/m		
Tapping fixtures	攻牙夾具	TC312 - #1		
Air pressure	空壓壓力	6 kg - 8 kg		
Package Size	包裝尺寸	900 m/m x 500 m/m x 200 m/m		
Net Weight	淨重	26 kg		

Standard Accessories:

- Air tapping spindle
- Parallel arm
- Table mounting column
- Thread taps not included
- Air unit
- Choose any six safety clutch tapping adapters
- Radial jib

標準配件:

- 氣動攻牙主軸
- 平行手臂
- 固定座
- 此產品不含螺絲攻
- 三點組合
- 絲功扭力筒夾 6 / PC
- 旋臂



Vertical Air Tapping Machine
立式氣壓攻牙機
GT-10VM | GT-12VM | GT-16VM

Model	型號	GT-10VM	GT-12VM	GT-16VM
Tapping capacity	攻牙能力	M3 - M10	M3 - M14	M3 - M16
Speed RPM	主軸轉速	700 rpm	400 rpm	300 rpm
Work Range	工作範圍	250 m/m - 1500 m/m		
Tapping fixtures	攻牙夾具	TC312 - #1		
Air pressure	空壓壓力	6 kg - 8 kg		
Package Size	包裝尺寸	900 m/m x 500 m/m x 200 m/m		
Net Weight	淨重	25 kg		



Universal Air Tapping Machine
萬向氣壓攻牙機
GT-10HM | GT-12HM | GT-16HM

Model	型號	GT-10HM	GT-12HM	GT-16HM
Tapping capacity	攻牙能力	M3 - M10	M3 - M14	M3 - M16
Speed RPM	主軸轉速	700 rpm	400 rpm	300 rpm
Work Range	工作範圍	250 m/m - 1500 m/m		
Tapping fixtures	攻牙夾具	TC312 - #1		
Air pressure	空壓壓力	6 kg - 8 kg		
Package Size	包裝尺寸	900 m/m x 500 m/m x 200 m/m		
Net Weight	淨重	25 kg		

Standard Accessories:

- Air tapping spindle
- Parallel arm
- Table mounting column
- Thread taps not included
- Air unit
- Choose any six safety clutch tapping adapters
- Radial jib

標準配件：

- 氣動攻牙主軸
- 平行手臂
- 固定座
- 此產品不含螺絲攻
- 三點組合
- 絲功扭力筒夾 6 / PC
- 旋臂



Vertical Air Tapping Machine
立式氣壓攻牙機
GT-10VS | GT-12VS | GT-16VS

Model	型號	GT-10VS	GT-12VS	GT-16VS
Tapping capacity	攻牙能力	M3 - M10	M3 - M14	M3 - M16
Speed RPM	主軸轉速	700 rpm	400 rpm	300 rpm
Work Range	工作範圍	200 m/m - 1100 m/m		
Tapping fixtures	攻牙夾具	TC312 - #1		
Air pressure	空壓壓力	6 kg - 8 kg		
Package Size	包裝尺寸	900 m/m x 500 m/m x 200 m/m		
Net Weight	淨重	21 kg		



Universal Air Tapping Machine
萬向氣壓攻牙機
GT-10HS | GT-12HS | GT-16HS

Model	型號	GT-10HS	GT-12HS	GT-16HS
Tapping capacity	攻牙能力	M3 - M10	M3 - M14	M3 - M16
Speed RPM	主軸轉速	700 rpm	400 rpm	300 rpm
Work Range	工作範圍	200 m/m - 1100 m/m		
Tapping fixtures	攻牙夾具	TC312 - #1		
Air pressure	空壓壓力	6 kg - 8 kg		
Package Size	包裝尺寸	900 m/m x 500 m/m x 200 m/m		
Net Weight	淨重	21 kg		

Standard Accessories:

- Air tapping spindle
- Parallel arm
- Table mounting column
- Thread taps not included
- Air unit
- Choose any six safety clutch tapping adapters
- Radial jib

標準配件：

- 氣動攻牙主軸
- 平行手臂
- 固定座
- 此產品不含螺絲攻
- 三點組合
- 絲功扭力筒夾 6 / PC
- 旋臂



Vertical Air Tapping Machine
立式氣壓攻牙機
GT-10VL II | GT-12VL II | GT-16VL II

Model	型號	GT-10VL II	GT-12VL II	GT-16VL II
Tapping capacity	攻牙能力	M3 - M10	M3 - M14	M3 - M16
Speed RPM	主軸轉速	700 rpm	400 rpm	300 rpm
Work Range	工作範圍	500 m/m - 1600 m/m		
Tapping fixtures	攻牙夾具	TC312 - #1		
Air pressure	空壓壓力	6 kg - 8 kg		
Package Size	包裝尺寸	900 m/m x 500 m/m x 200 m/m		
Net Weight	淨重	23 kg		



Universal Air Tapping Machine
萬向氣壓攻牙機
GT-10HL II | GT-12HL II | GT-16HL II

Model	型號	GT-10HL II	GT-12HL II	GT-16HL II
Tapping capacity	攻牙能力	M3 - M10	M3 - M14	M3 - M16
Speed RPM	主軸轉速	700 rpm	400 rpm	300 rpm
Work Range	工作範圍	500 m/m - 1600 m/m		
Tapping fixtures	攻牙夾具	TC312 - #1		
Air pressure	空壓壓力	6 kg - 8 kg		
Package Size	包裝尺寸	900 m/m x 500 m/m x 200 m/m		
Net Weight	淨重	23 kg		

Standard Accessories:

- Air tapping spindle
- Parallel arm
- Table mounting column
- Thread taps not included
- Air unit
- Choose any six safety clutch tapping adapters

標準配件：

- 氣動攻牙主軸
- 平行手臂
- 固定座
- 此產品不含螺絲攻
- 三點組合
- 絲功扭力筒夾 6 / PC



Vertical Air Tapping Machine
立式氣壓攻牙機
GT-20VL | GT-24VL

Model	型號	GT-20VL	GT-24VL
Tapping capacity	攻牙能力	M3 - M20	M3 - M24
Speed RPM	主軸轉速	500 / 160 rpm	250 / 90 rpm
Work Range	工作範圍	400 m/m - 2500 m/m	
Tapping fixtures	攻牙夾具	TC820 - #2	
Air pressure	空壓壓力	6 kg - 8 kg	
Package Size	包裝尺寸	1360 m/m x 660 m/m x 320 m/m	
Net Weight	淨重	45 kg	
Gross Weight	毛重	75 kg	



Universal Air Tapping Machine
萬向氣壓攻牙機
GT-20HL | GT-24HL

Model	型號	GT-20HL	GT-24HL
Tapping capacity	攻牙能力	M3 - M20	M3 - M24
Speed RPM	主軸轉速	500 / 160 rpm	250 / 90 rpm
Work Range	工作範圍	400 m/m - 2500 m/m	
Tapping fixtures	攻牙夾具	TC820 - #2	
Air pressure	空壓壓力	6 kg - 8 kg	
Package Size	包裝尺寸	1460 m/m x 660 m/m x 320 m/m	
Net Weight	淨重 (kg)	45 kg	
Gross Weight	毛重	75 kg	

Standard Accessories:

- Air tapping spindle
- Parallel arm
- Table mounting column
- Thread taps not included
- Air unit
- Choose any six safety clutch tapping adapters
- Radial jib

標準配件：

- 氣動攻牙主軸
- 平行手臂
- 固定座
- 此產品不含螺絲攻
- 三點組合
- 絲功扭力筒夾 6 / PC
- 旋臂



Vertical Air Tapping Machine
立式氣壓攻牙機
GT-20VM / GT-24VM

Model	型號	GT-20VM	GT-24VM
Tapping capacity	攻牙能力	M3 - M20	M3 - M24
Speed RPM	主軸轉速	500 / 160 rpm	250 / 90 rpm
Work Range	工作範圍	400 m/m - 2000 m/m	
Tapping fixtures	攻牙夾具	TC820 - #2	
Air pressure	空壓壓力	6 kg - 8 kg	
Package Size	包裝尺寸	1360 m/m x 660 m/m x 320 m/m	
Net Weight	淨重	45 kg	
Gross Weight	毛重	75 kg	

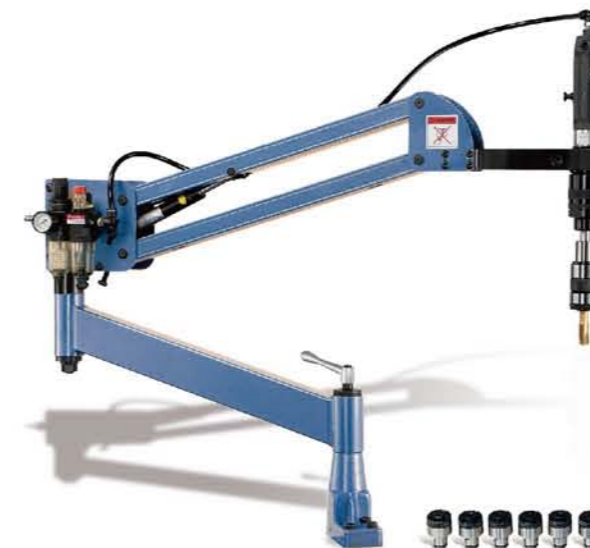

Vertical Air Tapping Machine
立式氣壓攻牙機
GT-20VS / GT-24VS

Model	型號	GT-20VS	GT-24VS
Tapping capacity	攻牙能力	M3 - M20	M3 - M24
Speed RPM	主軸轉速	500 / 160 rpm	250 / 90 rpm
Work Range	工作範圍	300 m/m - 1600 m/m	
Tapping fixtures	攻牙夾具	TC820 - #2	
Air pressure	空壓壓力	6 kg - 8 kg	
Package Size	包裝尺寸	1270 m/m x 660 m/m x 320 m/m	
Net Weight	淨重	35 kg	
Gross Weight	毛重	60 kg	



Universal Air Tapping Machine
萬向氣壓攻牙機
GT-20HM / GT-24HM

Model	型號	GT-20HM	GT-24HM
Tapping capacity	攻牙能力	M3 - M20	M3 - M24
Speed RPM	主軸轉速	500 / 160 rpm	250 / 90 rpm
Work Range	工作範圍	400 m/m - 2000 m/m	
Tapping fixtures	攻牙夾具	TC820 - #2	
Air pressure	空壓壓力	6 kg - 8 kg	
Package Size	包裝尺寸	1360 m/m x 660 m/m x 320 m/m	
Net Weight	淨重	45 kg	
Gross Weight	毛重	75 kg	



Universal Air Tapping Machine
萬向氣壓攻牙機
GT-20HS / GT-24HS

Model	型號	GT-20HS	GT-24HS
Tapping capacity	攻牙能力	M3 - M20	M3 - M24
Speed RPM	主軸轉速	500 / 160 rpm	250 / 90 rpm
Work Range	工作範圍	300 m/m - 1600 m/m	
Tapping fixtures	攻牙夾具	TC820 - #2	
Air pressure	空壓壓力	6 kg - 8 kg	
Package Size	包裝尺寸	1270 m/m x 660 m/m x 320 m/m	
Net Weight	淨重	35 kg	
Gross Weight	毛重	60 kg	

Standard Accessories:

- Air tapping spindle
- Parallel arm
- Table mounting column
- Thread taps not included
- Air unit
- Choose any six safety clutch tapping adapters

標準配件：

- 氣動攻牙主軸
- 平行手臂
- 固定座
- 此產品不含螺絲攻
- 三點組合
- 絲功扭力筒夾 6 / PC

Standard Accessories:

- Air tapping spindle
- Parallel arm
- Table mounting column
- Thread taps not included
- Air unit
- Choose any six safety clutch tapping adapters
- Radial jib

標準配件：

- 氣動攻牙主軸
- 平行手臂
- 固定座
- 此產品不含螺絲攻
- 三點組合
- 絲功扭力筒夾 6 / PC
- 旋臂

HT-Series

HT-Series Air Tapping Machine HT 系列氣壓攻牙機

Numbering system for HT-Series

1. "HT" stands for series of Wellcam hydraulic tapping machines
2. HT "20,24,36" stands for tapping capacity of hydraulic motor & RPM specification.
3. "V" (Vertical stands for vertical tapping, "H" (Horizontal) stands for horizontal tapping.
4. "L" stands for the longer size of tapping arm (working area)

Features for HT-Series

1. HT-Series All series are using parts that comply with EU standards and get CE compliance certification.
2. HT-Series Module component designed that makes the maintenance easier.
3. HT-Series Simplified operation without any complicated adjustment for hydraulic pressure or speed control.
4. HT-20 & HT-24 Series Good for M12-M24 mass tapping process. Suitable for harder work pieces like medium-carbon steel, die steel, stainless steel. Varied of application covering the tapping for die set, valves, hydraulic valves, pneumatic valve, thicker steel plate, SS plate....etc. Increase the production efficiency and production capacity.
5. HT-36 Series Suitable for tapping larger size, such as M16-M36, PT 3/4, PT 1". Bigger tapping torque, stabilized processing, longer lifespan.

HT 系列產品編號方式說明

1. 「HT」屬於 WELLCAM 產品，油壓系列攻牙機代表編號。
2. 「HT- 20、24、36」，代表每一款型號油壓馬達攻牙能力及油壓動力，主軸 RPM 規格之選擇編號。
3. 「V」(Vertical) 表示垂直攻牙作業產品代碼，「H」(Horizontal) 表示水平側向攻牙作業產品代碼。
4. 「L」代表 Tapping Arm 加長型產品工作範圍之代碼。

HT 系列產品特性介紹

1. HT 系列產品全機採用歐規安全標準電器零件，HT 系列並已取得符合歐規 CE 認證標準。
2. HT 系列產品組裝零件採模組化設計，維修容易。
3. HT 系列產品操作簡易化，不需複雜的油壓壓力及轉速調整操作控制，操作技術門檻低，簡易方便。
4. HT-20 及 HT-24 系列適用於 M12-M24 量產型攻牙作業及較硬材料攻牙作業，材料例如：中碳鋼、模具鋼、不銹鋼、實際運用於、模座、水閥、油壓閥、氣壓閥、較厚鋼板、不銹鋼鋼板等，產品之攻牙作業，提高生產效率，增加產能。
5. HT-36 系列適用於 M16-M36、PT 3/4、PT 1" 大尺寸攻牙規格、攻牙扭力大、穩定性高、使用壽命長。

Vertical Air Tapping Machine 立式氣壓攻牙機

GT-20VM II | GT-24VM II

Model	型號	GT-20VM II	GT-24VM II
Tapping capacity	攻牙能力	M3 - M20	M3 - M24
Speed RPM	主軸轉速	500 / 160 rpm	250 / 90 rpm
Work Range	工作範圍	400 m/m - 1400 m/m	
Tapping fixtures	攻牙夾具	TC820 - #2	
Air pressure	空壓壓力	6 kg - 8 kg	
Package Size	包裝尺寸	1360 m/m x 660 m/m x 320 m/m	
Net Weight	淨重	40 kg	
Gross Weight	毛重	70 kg	

Universal Air Tapping Machine 萬向氣壓攻牙機

GT-20HM II | GT-24HM II

Model	型號	GT-20HM II	GT-24HM II
Tapping capacity	攻牙能力	M3 - M20	M3 - M24
Speed RPM	主軸轉速	500 / 160 rpm	250 / 90 rpm
Work Range	工作範圍	400 m/m - 1400 m/m	
Tapping fixtures	攻牙夾具	TC820 - #2	
Air pressure	空壓壓力	6 kg - 8 kg	
Package Size	包裝尺寸	1360 m/m x 660 m/m x 320 m/m	
Net Weight	淨重	40 kg	
Gross Weight	毛重	70 kg	

Standard Accessories:

- Air tapping spindle
- Parallel arm
- Table mounting column
- Thread taps not included
- Air unit
- Choose any six safety clutch tapping adapters

標準配件：

- 氣動攻牙主軸
- 平行手臂
- 固定座
- 此產品不含螺絲攻
- 三點組合
- 絲功扭力筒夾 6 / PC



Vertical Hydraulic Tapping Machine
 立式油壓攻牙機
HT-20V | HT-24V | HT-36V

Model	型號	HT-20V	HT-24V	HT-36V
Tapping capacity	攻牙能力	M5 - M20	M5 - M24	M5 - M36
Speed RPM	主軸轉速	50 / 500 rpm	50 / 350 rpm	50 / 200 rpm
Work Range	工作範圍	500 m/m - 2000 m/m		
Tapping fixtures	攻牙夾具	#2 - TC820	#3 - TC1433	
Hydraulic Pressure	油壓壓力	120 kg		150 kg
Motor	馬達	5HP		
Power supply	額定電壓	AC 220V / 380V, 50 / 60 HZ, 3-PHASE		
Bench Dimension	工作桌尺寸	850 m/m x 680 m/m x 870 m/m		
Package Size	包裝尺寸	1190 m/m x 1190 m/m x 1160 m/m (Wood Case)		
Net Weight	淨重	350 kg		
Gross Weight	毛重	450 kg		



Universal Hydraulic Tapping Machine
 萬向油壓攻牙機
HT-20H | HT-24H | HT-36H

Model	型號	HT-20H	HT-24H	HT-36H
Tapping capacity	攻牙能力	M5 - M20	M5 - M24	M5 - M36
Speed RPM	主軸轉速	50 / 500 rpm	50 / 350 rpm	50 / 200 rpm
Work Range	工作範圍	500 m/m - 2000 m/m		
Tapping fixtures	攻牙夾具	#2 - TC820	#3 - TC1433	
Hydraulic Pressure	油壓壓力	120 kg		150 kg
Motor	馬達	5 HP		
Power supply	額定電壓	AC 220V / 380V, 50 / 60 HZ, 3-PHASE		
Bench Dimension	工作桌尺寸	850 m/m x 680 m/m x 870 m/m		
Package Size	包裝尺寸	Table:1140 m/m x 990 m/m x 1190 m/m (Wood Case) Arm:1340 m/m x 650 m/m x 470 m/m (Wood Case)		
Net Weight	淨重	Table:310 kg , Arm:66 kg		
Gross Weight	毛重	Table:380 kg , Arm:125 kg		

Standard Accessories:

- Hydraulic tapping spindle
- Parallel arm
- Table mounting column
- Radial jib
- Neither hydraulic oil (R32 or R68) nor thread taps are included
- Work Table
- Electric - Controlled Device
- Electric Motor, Hydraulic Pump, Hydraulic Box
- Choose any six safety clutch tapping adapters

標準配件：

- 油壓攻牙機主軸
- 平行手臂
- 固定座
- 旋臂
- 本產品不含R32或R68液壓油及螺絲攻
- 工作桌
- 電器控制箱
- 油壓系統
- 絲功扭力筒夾 6 / PC



Vertical Hydraulic Tapping Machine
 立式油壓攻牙機
HT-20VL | HT-24VL | HT-36VL

Model	型號	HT-20VL	HT-24VL	HT-36VL
Tapping capacity	攻牙能力	M5 - M20	M5 - M24	M5 - M36
Speed RPM	主軸轉速	50 / 500 rpm	50 / 350 rpm	50 / 200 rpm
Work Range	工作範圍	500 m/m - 2500 m/m		
Tapping fixtures	攻牙夾具	#2 - TC820	#3 - TC1433	
Hydraulic Pressure	油壓壓力	120 kg		150 kg
Motor	馬達	5HP		
Power supply	額定電壓	AC 220V / 380V, 50 / 60 HZ, 3-PHASE		
Bench Dimension	工作桌尺寸	850 m/m x 680 m/m x 870 m/m		
Package Size	包裝尺寸	Table:1140 m/m x 990 m/m x 1190 m/m (Wood Case) Arm:1590 m/m x 650 m/m x 470 m/m (Wood Case)		
Net Weight	淨重	Table:310 kg , Arm:66 kg		
Gross Weight	毛重	Table:380 kg , Arm:135 kg		



Universal Hydraulic Tapping Machine
 萬向油壓攻牙機
HT-20HL | HT-24HL | HT-36HL

Model	型號	HT-20HL	HT-24HL	HT-36HL
Tapping capacity	攻牙能力	M5 - M20	M5 - M24	M5 - M36
Speed RPM	主軸轉速	50 / 500 rpm	50 / 350 rpm	50 / 200 rpm
Work Range	工作範圍	500 m/m - 2500 m/m		
Tapping fixtures	攻牙夾具	#2 - TC820	#3 - TC1433	
Hydraulic Pressure	油壓壓力	120 kg		150 kg
Motor	馬達	5 HP		
Power supply	額定電壓	AC 220V / 380V, 50 / 60 HZ, 3-PHASE		
Bench Dimension	工作桌尺寸	850 m/m x 680 m/m x 870 m/m		
Package Size	包裝尺寸	Table:1140 m/m x 990 m/m x 1190 m/m (Wood Case) Arm:1590 m/m x 650 m/m x 470 m/m (Wood Case)		
Net Weight	淨重	Table:310 kg , Arm:66 kg		
Gross Weight	毛重	Table:380 kg , Arm:135 kg		

Standard Accessories:

- Hydraulic tapping spindle
- Parallel arm
- Table mounting column
- Radial jib
- Neither hydraulic oil (R32 or R68) nor thread taps are included
- Work Table
- Electric - Controlled Device
- Electric Motor, Hydraulic Pump, Hydraulic Box
- Choose any six safety clutch tapping adapters

標準配件：

- 油壓攻牙機主軸
- 平行手臂
- 固定座
- 旋臂
- 本產品不含R32或R68液壓油及螺絲攻
- 工作桌
- 電器控制箱
- 油壓系統
- 絲功扭力筒夾 6 / PC

ED - Series

ED-Series Drilling Machine ED 系列鑽孔機

1. Compact type makes the operation easier and more convenient.
2. In 90 or other angles to proceed drilling used for several function and application.
3. Wider working range so that works in a more flexible way.
Chamfer and hole reaming can be easily done.



1. 便利輕巧的鑽孔加工
2. 可選擇 90 度垂直或多角鑽孔，多用途，功能性強
3. 工作範圍大，應用範圍廣，亦可倒角及絞孔

Vertical AE Universal Drilling Machine 立式 / 萬向鑽孔機

ED-10V-1 | ED-10H-1 | ED-10V-2 | ED-10H-2

Model	型號	ED-10V-1	ED-10H-1	ED-10V-2	ED-10H-2
Drilling capacity	鑽孔能力		1 m/m - 13 m/m		
Speed RPM	主軸轉速		0 - 2800 rpm		
Work Range	工作範圍		300 m/m - 2000 m/m		
Power supply	額定電壓	110 V / 50 HZ		220 V / 50 HZ	
Package Size	包裝尺寸	900 m/m x 500 m/m x 200 m/m			
Net Weight	淨重	23 kg			

Standard Accessories:

- Drill
- Parallel arm
- Table mounting column
- Radial jib

標準配件：

- 電鑽
- 平行手臂
- 固定座
- 旋臂



Optional Accessories



Optional Accessories of Tapping Machine 功牙機選配裝置



Working Table 工作桌 AT-007

Model	型號	AT-007
Net Weight	淨重	155 kg
Gross Weight	毛重	220 kg
Working Table	工作桌尺寸	850 mm x 680 mm x 870 mm
Package Size	包裝尺寸	950 mm x 820 mm x 1080 mm

Portable Permanent Magnetic Base 手提式磁性座



GPL-600



GPL-300

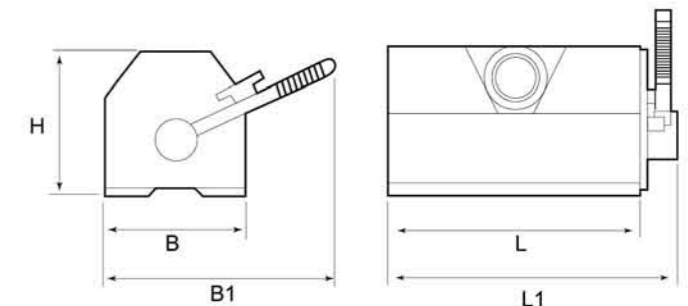

Model 型式	Magnetic base 磁性座		Model for machine 適合機型	Chucking face 吸著面		Dimensions 外部面積尺寸 (mm)		
	Capacity 吊重能力	Packing dimensions 包裝尺寸 (LxWxH)		B	L	H	B1	L1
GPL-300	300 kg	22 cm x 13 cm x 16 cm	GT-10VM,GT-12VM,GT-16VM GT-10VM II,GT-12VM II,GT-16VM II GT-10VS,GT-12VS,GT-16VS	93	165	96	210	185
GPL-600	600 kg	30 cm x 16 cm x 16 cm	GT-10VL,GT-12VL,GT-16VL GT-10VL II,GT-12VL II,GT-16VL II	122	236	120	303	265

Model 型式	Steel Plate 鐵板		Not hollow round steel 實心圓鐵				
	Max. Lifting capacity 吊重能力	Min. thickness required 最小厚度需求	Max. Lifting capacity 吊重能力	Max. diameter 最大直徑	Max. length 最大長度	Safety coefficient 安全係數	Weight 重量
GPL-300	300 kg	25 mm	135 kg	250 mm	1500 mm	X 3.5	11 kg
GPL-600	600 kg	30 mm	270 kg	350 mm	2000 mm	X 3.5	26 kg

※ 使用手提式磁性座，需注意最小厚度需求。

※ Pay attention to the minimum thickness required while using "Portable permanent Magnetic Base"

90° and Various Degree Tapping Device
90° 萬向攻牙轉換器



Model	Weight
GT-10-90°	1.5 kg
GT-12-90°	1.5 kg
GT-16-90°	1.5 kg



Model	Weight
GT-20-90°	3.5 kg
GT-24-90°	3.5 kg

※ HT 油壓系列產品無法另外加裝90度萬向轉換器
 ※ "90 and Various Degree Tapping Device" is not adoptable for HT hydraulic series

Air Tapping Spindle Series
氣動攻牙主軸系列



Model	型式	GT-031	GT-032	GT-033	GT-034	GT-035
Tapping Capacity	攻牙能力	M3 - M10	M3 - M14	M3 - M16	M3 - M20	M3 - M24
Air Pressure	空氣壓力	6 - 8 kg / cm ²	6 - 8 kg / cm ²	6 - 8 kg / cm ²	6 - 8 kg / cm ²	6 - 8 kg / cm ²
Speed	轉速	700 rpm	400 rpm	300 rpm	500 / 160 rpm	250 / 90 rpm
Wight	重量	2.5 kg	2.5 kg	2.5 kg	4 kg	4 kg

※ 本產品不含 Tap Collets 及 Thread Taps
 ※ Tap collets and thread taps not included

BROKEN TAP REMOVER **ISO-9001 CE**
牙攻去除機 **LS-100**

■ APPLICATION \ 用途

1. Suitable for removal of Various Hardened material such as Broken screws, Taps, Drill bits, Gauges..etc. Including Other Cutting tools and tools.
 2. Can Work on Different sizes, Diameters and Shapes of Workpiece.
 3. A Versatile High Efficiency, Low cost Operation.
1. 取出各種硬質物件，如破損的 TAP、螺絲、量規、其他刀具等。
 2. 各種不同尺寸，不同型錄之工件也都適用。
 3. 多功能、高效率、低成本。



■ FEATURES & FUNCTION.

1. Utilising Spark Erosion method to remove Broken parts of Cutting tools Or Screws, No damage to Workpiece, Due to cutting force generated.
2. It is of Portable design and Its Magnetic base, Allows to be easily clamped on Top of Workpiece for Machining.
3. It's a Self-Contained unit, Complete with Dielectric Pump and Central cooling for Electrode Holder.
4. The workhead is Mounted on a +/- 60 Degree angle Slide plate.
5. With simple Easy-to-understand Operating panel on Controller.
6. With Automatic cutting depth control. Maximum Z-axis depth setting : 100mm. and Z-axis up / down Max. Travel : 300mm.

■ 特性與功能

1. 採用電蝕原理去除折斷刀具，非接觸加工，加工中不受力，不會損傷工件。
2. 採用磁性底座，加工裝置可以吸到工件上加工，便攜式設計，可以方便的在各種環境下使用。
3. 內置工作液幫浦-電極中心出水。
4. 工作機頭可任意角度調整。
5. 圖面化面板簡單易操作。
6. 加工深度自動控制。

■ SPECIFICATION \ 規格

MODEL	規格	單位	LS-100
Electrode diameter Range	電極直徑範圍	mm	φ 1.2 - φ 6.0
Machine Unit Net weight	機器淨重	kgs	6
Machine dimensions (W x D x H)	機器尺寸	mm	240 x 60 x 410
Generator Unit Net weight	電源箱重量	kgs	30
Generator dimension (W x D x H)	電源箱尺寸	mm	310 x 260 x 200
Generator Power Input	電源箱輸入電源		220 Volt. 1-Phase, (50 / 60 Hz.) / 110 Volt. 1-Phase, (50 / 60 Hz.)
Maximum Current Output	最大電流輸出	Amp.	10 A.
Total AC Power Input	總輸入交流電	KVA	1.2 KVA
Dielectric Fluid	絕緣液		Clean Water 乾淨水
Electrode Material	電極材質		Brass Bar & Sheet 銅棒、銅片
Packing Dimension (Carton packing)	紙箱包裝明細	mm	520 L x 440 W x 270 H
Total Weight (Carton Packing)	總毛重(紙箱)	kgs	40
Wooden Crate Packing Dimension	條箱包裝	mm	590 L x 515 W x 400 H
Wooden Crate Packing Weight	條箱包裝毛重	kgs	50

■ TYPICAL WORK TIMES \ 標準工作時間

TAP DIA. 牙攻直徑	DEPTH 加工深度	ELECTRODE DIA. 電極直徑	TIME 時間
M6	10mm	φ 3	7 min
M8	10mm	φ 4	9 min
M10	10mm	φ 5	13 min
M12	10mm	φ 6	16 min

■ STANDARD ACCESS. \ 標準配件

1. MACHINE UNIT With Magnetic Base. / 機器磁性座
2. GENERATOR UNIT. / 電源箱
3. SMALL PUMP UNIT FOR Dielectric Fluid. / 工作液幫浦
4. ELECTRODE CHUCK. / 電極夾頭
5. BRASS ELECTRODE. (SIZE AS BELOW) / 黃銅棒
 - φ 1.2mm DIA. X 4 Pieces
 - φ 2.0mm DIA. X 2 Pieces
 - φ 2.5mm DIA. X 2 Pieces
 - φ 3.0mm DIA. X 2 Pieces
 - φ 4.0mm DIA. X 1 Piece
 - φ 5.0mm DIA. X 1 Piece
 - φ 6.0mm DIA. X 1 Piece
- BRASS SHEET & FIXED HOLDER. X 1 Set. / 銅片、固定架 一組

Cutting Method \ 加工方法

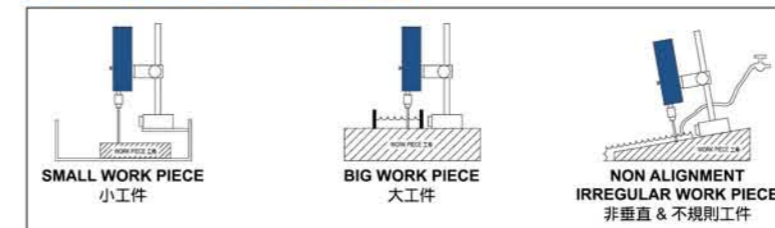

Overall Dimension \ 外觀尺寸

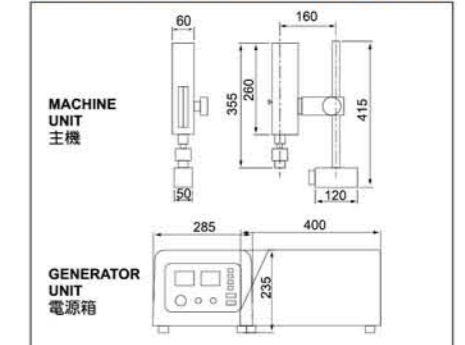

Swivel Work Head \ 機頭移動

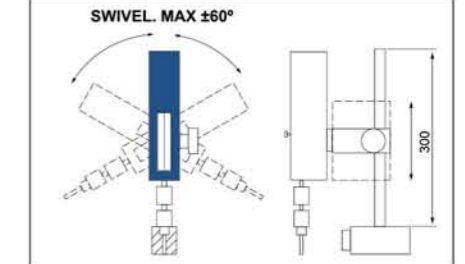

Cutting Method \ 去除斷裂牙攻方式

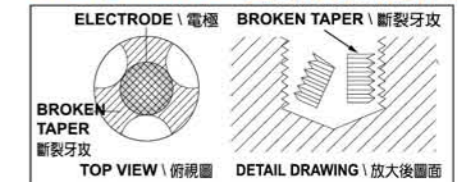

Collets Adapter
轉接器

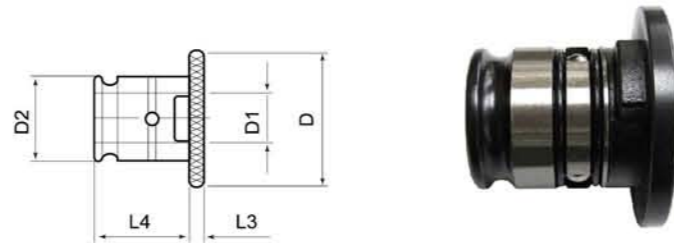

Model	Suitable Adapters Size	For Adapters Size	D	D1	D2	L3	L4	Weight (kg)
TC820 (#2) / TC312 (#1)	2	1	48	19	31	5	35	0.17
TC1433 (#3) / TC820 (#2)	3	2	70	31	48	6	55.5	0.6

Drill Chuck Collets
鑽孔夾頭

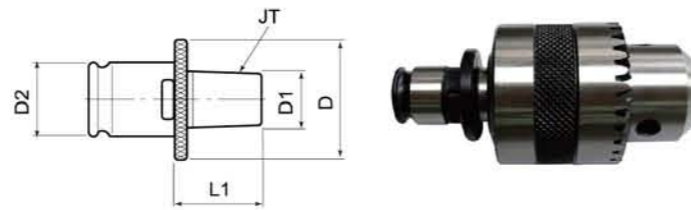

Model	For Drill Clfuck	Capacity (mm)	D	D1	D2	L1	Weight (kg)
TC312 (#1) / JT2	10H	0 - 10	30	13.94	19	31	0.6
TC312 (#1) / JT6	13H	0 - 12	30	17.17	19	34	0.6
TC820 (#2) / JT6	13H	0 - 12	48	17.17	31	37	0.3

Tc Quick Change Tap Collets (With Overload Clutch)

TC 快換絲攻筒夾 - 扭力裝置型

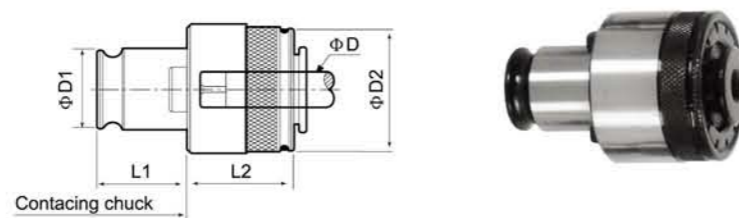

Model	Tapping Capacity	ΦD1	ΦD2	L1	L2
TC312 (#1)	M3 ~ M14	19.0	32.0	21.5	25.0
TC820 (#2)	M8 ~ M24	31.0	50.0	35.0	34.0
TC1433 (#3)	M14 ~ M36	48.0	72.0	55.5	45.0

Tap Collest With Qverload Clutch - JIS
絲攻筒夾 - 扭力裝置型 - JIS

JIS Tap 絲攻	Tap size 絲攻尺寸		TC312(#1) Ref. No. 訂購編號	TC820(#2) Ref. No. 訂購編號	TC1433(#3) Ref. No. 訂購編號
	ΦD 柄徑	Sq. hole 四方孔			
M2		3.0	2.5	010-00	
M3	#5.#6	4.0	3.2	010-01	
M4	M4.5 #8	5.0	4.0	010-02	
M5	M5.5 #10.3/16"	5.5	4.5	010-03	
M6	UNC1/4	6.0	4.5	010-04	
	UNC5/16	6.1	5.0	010-05	
M8	M7	6.2	5.0	010-06	020-01
M10	M9	7.0	5.5	010-07	020-02
	M11	8.0	6.0	010-08	020-03
M12		8.5	6.5	010-09	020-04
	UNC1/2	9.0	7.0	010-10	020-05
M14	M15	10.5	8.0	010-11	020-06
	UNC5/8	12.0	9.0		020-07
M16		12.5	10.0	010B-14	020-08
	M17	13.0	10.0		020-09
M18	UNC3/4	14.0	11.0		020-10
M20		15.0	12.0		020-11
M22	UNC7/8	17.0	13.0		020-12
M24	M25	19.0	15.0		020-13
M27	M26	20.0	15.0		030-09
M28		21.0	17.0		030-10
	UNC1 1/8	22.0	17.0		030-11
M30		23.0	17.0		030-12
M32	UNC1 1/4	24.0	19.0		030-13
M33		25.0	19.0		030-14
M35	M34	26.0	21.0		030-15
M36		28.0	21.0		030-16
PT1/8	PF1/8	8.0	6.0	010-12	020-14
PT1/4	PF1/4	11.0	9.0	010-13	020-15
PT3/8	PF3/8	14.0	11.0		020-16
PT1/2	PF1/2	18.0	14.0		020-17
PT3/4	PF3/4	23.0	17.0		030-19
PT1	PF1	26.0	21.0		030-20
					030-21

Tap Collets With Overload Clutch - DIN371

絲攻筒夾 - 扭力裝置型 - DIN371

DIN371 Tap 絲攻	Tap size 絲攻尺寸		TC312(#1) Ref. No. 訂購編號	TC820(#2) Ref. No. 訂購編號	TC1433(#3) Ref. No. 訂購編號
	ΦD 柄徑	Sq. hole 四方孔			
M1~M1.8	2.5	2.1	011-01		
M2~M2.5	2.8	2.1	011-02		
M3	3.5	2.7	011-03		
M3.5	4.0	3.0	011-04		
M4	4.5	3.4	011-05		
M4.5	6.0	4.9	011-06		
M5	6.0	4.9	011-07	021-01	
M6	6.0	4.9	011-08	021-02	
M8	8.0	6.2	011-09	021-03	
M10	10.0	8.0	011-10	021-04	

Tap Collets With Overload Clutch - DIN376

絲攻筒夾 - 扭力裝置型 - DIN376

DIN376 Tap 絲攻	Tap size 絲攻尺寸		TC312(#1) Ref. No. 訂購編號	TC820(#2) Ref. No. 訂購編號	TC1433(#3) Ref. No. 訂購編號
	ΦD 柄徑	Sq. hole 四方孔			
M3.5	2.5	2.1	012-01		
M4	2.8	2.1	012-02		
M4.5	3.5	2.7	012-03		
M5	3.5	2.7	012-04		
M6	4.5	3.4	012-05		
M7	5.5	4.3	012-06		
M8	6.0	4.9	012-07	022-01	
M10	7.0	5.5	012-08	022-02	
M12	9.0	7.0	012-09	022-03	
M14	11.0	9.0	012-10	022-04	032-01
M16	12.0	9.0	012B-11	022-05	032-02
M18	14.0	11.0		022-06	032-03
M20	16.0	12.0		022-07	032-04
M22	18.0	14.5		022-08	032-05
M24	18.0	14.5		022-09	032-06
M27	20.0	16.0			032-07
M30	22.0	18.0			032-08
M33	25.0	20.0			032-09
M36	28.0	22.0			032-10

Tap Collets With Overload Clutch - ISO529

絲攻筒夾 - 扭力裝置型 - ISO529

ISO529 Tap 絲攻	Tap size 絲攻尺寸		TC312(#1) Ref. No. 訂購編號	TC820(#2) Ref. No. 訂購編號	TC1433(#3) Ref. No. 訂購編號
	ΦD 柄徑	Sq. hole 四方孔			
M1~M2	2.5	2.0	013-01		
M2.2~M2.5	2.8	2.24	013-02		
M3	3.15	2.5	013-03		
M3.5	3.55	2.8	013-04		
M4	4.0	3.15	013-05		
M4.5	4.5	3.55	013-06		
M5	5.0	4.0	013-07		
M6	6.3	5.0	013-08	023-01	
M7	7.1	5.6	013-09	023-02	
M8	8.0	6.3	013-10	023-03	
M9	9.0	7.1	013-11	023-04	
M10	10.0	8.0	013-12	023-05	

Tap Collets With Overload Clutch - ISO529 / 2283

絲攻筒夾 - 扭力裝置型 - ISO529 / 2283

ISO529 / 2283 Tap 絲攻	Tap size 絲攻尺寸		TC312(#1) Ref. No. 訂購編號	TC820(#2) Ref. No. 訂購編號	TC1433(#3) Ref. No. 訂購編號
	ΦD 柄徑	Sq. hole 四方孔			
M3	2.24	1.8	014-01		
M3.5	2.5	2.0	014-02		
M4	3.15	2.5	014-03		
M4.5	3.55	2.8	014-04		
M5	4.0	3.15	014-05		
M6	4.5	3.55	014-06		
M7	5.6	4.5	014-07		
M8	6.3	5.0	014-08	024-01	
M9	7.1	5.6	014-09	024-02	
M10	8.0	6.3	014-10	024-03	
M12	9.0	7.1	014-11	024-04	
M14	11.2	9.0	014-12	024-05	034-01
M16	12.5	10.0	014B-13	024-06	034-02
M18	14.0	11.2		024-07	034-03
M20	14.0	11.2		024-08	034-04
M22	16.0	12.5		024-09	034-05
M24	18.0	14.0		024-10	034-06
M27	20.0	16.0			034-07
M30	20.0	16.0			034-08
M33	22.4	18.0			034-09
M36	25.0	20.0			034-10

NO.

Date / /

NO.

Date / /