

CNC Turret Punch

HPE HPC HPI HPH

 **Yawei** 亚威

Stock Code 002559

Continuous Optimization Reliable and Efficient

Product Catalogue

Continuous Optimization Reliable and Efficient	02
HPE Series	04
HPA Series	10
HPI Series	14
HPH Series	18
Common Parts	22
CNC Controller	26
Programming Software	27

Adopts CNC Turret Punch technology from NISSHINBO, Japan, YAWEI manufactures international first-class level CNC Turret Punch, serves all kinds of material forming industry, have a wide range of high-end customers.

YAWEI focus on research and innovation for years, and offering the best punching and forming solutions by different model of mature products and parts.

CNC Hydraulic Turret Punch

- Complete new industrial design with delightful appearance
- Innovative application of all sorts turret punch technology, more efficient more energy-saving, and environment friendly
- Better specification and configuration, more powerful function, and easy operation



HPE Series

High-performance Mechanical Servo CNC Turret Punch

- Energy-efficient electric servo punch system, integrated with multi-axis linkage control and gap compensation device, can realize high efficient performance, quiet operation, precise positioning, lower inner deterioration, longer life span and nice processing quality



HPC Series

Universal Mechanical Servo CNC Turret Punch

- Trustworthy Yawei quality
- Suitable for high quality punching processing for various types of workpieces
- Full electric servo control is more energy-saving and environmentally friendly



HPI Series

High-efficiency Hydraulic Turret Punch

- Mature control and processing technology, suitable for middle class market and meet all kinds of complicated forming, can realize multi-axis linkage, improved the processing efficiency



HPH Series

High Cost Performance Hydraulic CNC Turret Punch

- Locates in middle-end market, HPH classic configuration with mature technology makes machine stable and durable

HPE Series CNC Turret Punch



- Electric servo control punch head for fast punching performance, marking frequency up to 2,300 hits/min
- All-touch HMI operation interface, powerful functions CNC controller
- Precise ram positioning control, the BDC positioning accuracy is 0.01mm
- Nisshinbo patented keeping-touch Auto-index technology, high repositioning precision
- Efficient precision roll forming
- Energy saving, low power consumption with low noise

HPE Series CNC Turret Punch

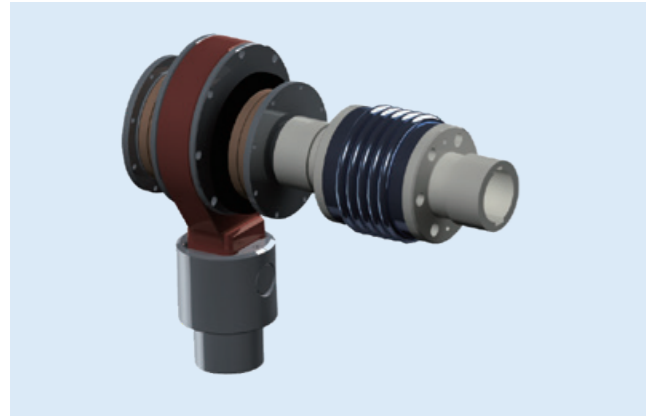

Servo Ram Design

- Ram design uses a single servo motor coupled directly to the crankshaft for highest punching performance and reliability. Simplified design enhances component life and ensures positioning accuracy by a closed loop servo control system

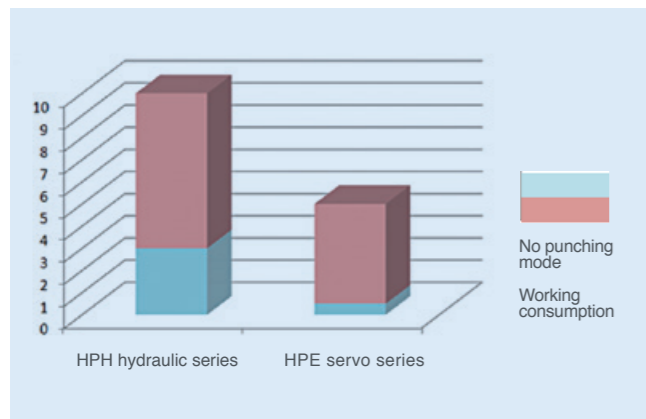

Energy Efficiency

- Realize high energy efficiency by calculating and controlling the punch force. Additionally, energy generated from break will be recycled for second acceleration. The consumption will be only half of hydraulic punch
- Complete servo control without hydraulic oil, low maintenance cost

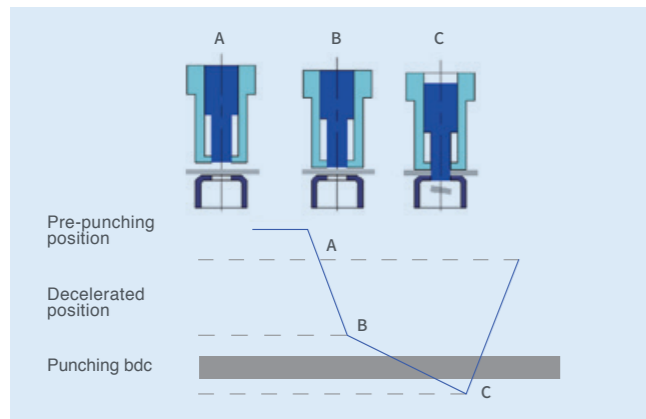

High Speed, Low Noise

- Advanced punching technology provides full control of ram speeds, stroke and forming combined with low noise and energy consumption
- High-precision seamless mechanical structure, no internal abnormal noise during high-speed movement



Turret Structure

- Turret processed through one-time clamp precision machining with high strength alloy casting steel, strong antioxidant and carrying capacity, excellent vibration and precision-oriented performance, less tool stuck, strip or other phenomena, and effectively reduce the plate deformation when punching high-density holes
- Guide bushing with precision machining, significantly increasing the tool life

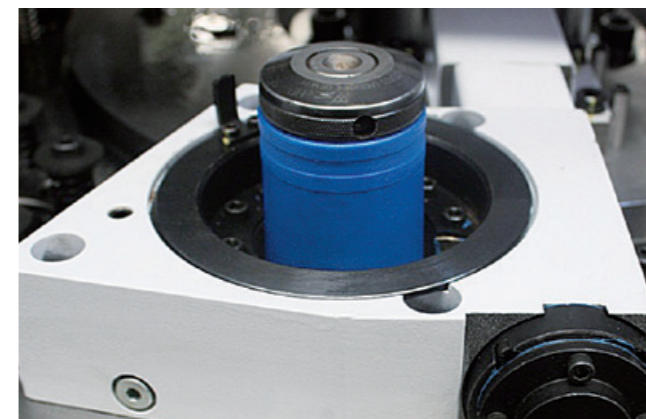

Tool Auto-index

- Nisshinbo patented keeping-touch Auto-index design eliminates secondary positioning errors, make the repositioning precision within 0.03mm by linkage transmission control of T axis, worm gear and rod

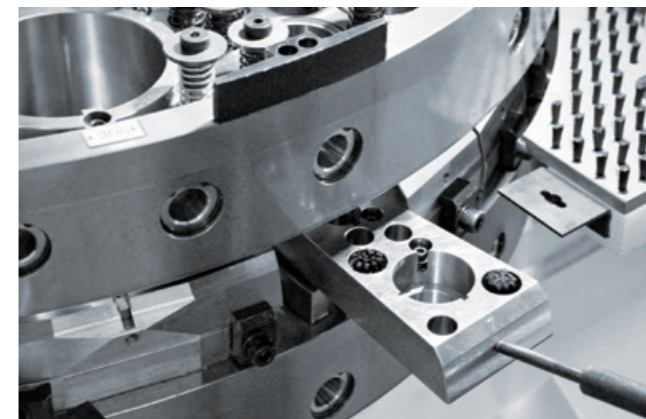

Lower Die Holder, Fast Change

- Special die removal device shortens the changing time, rises the work efficiency, precise positioning device guarantees the repositioning accuracy

HPE Series CNC Turret Punch



All-touch HMI Interface

- Adopts 17 inches all-touch HMI interface, which developed especially for turret punch, easy operation and powerful functions
- Integrated functions such like off-line simulation, dynamic simulation, tool comparison and so on

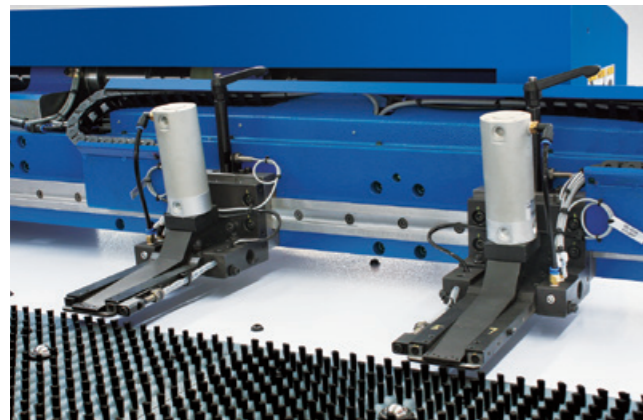

Feeding Structure

- Long stroke double-precision grinding ball screw rod without using segmented compensation during control, higher positioning accuracy, smaller noise and resistance, longer life time
- Standard swing type pneumatic clamps, mature and stable, can be adapted to sheet deformation to ensure the long term stable operation

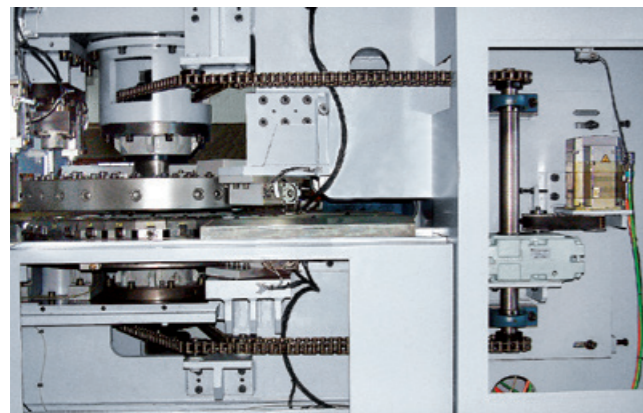

Turret Drive

- Compact structure with reasonable loading force distribution enables the fast and stable transmission, the precise turret positioning device guarantees the accuracy of tools selection

Standard Configuration

- Siemens CNC Controller
- Electric servo ram designed by Yawei
- 38 station turret with 2 auto-index station (2B station)
- Equipped with automatic lubrication for machine and sheet metal deformation sensors

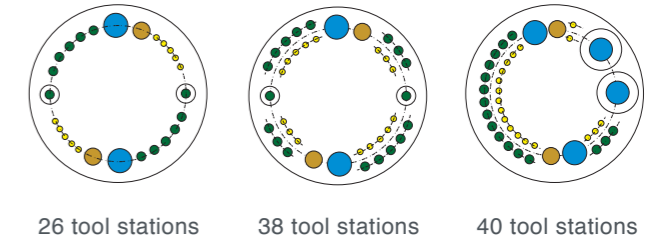

Tool station category	Symbol	26 tool stations		38 tool stations		40 tool stations		Dimension range
		NO	AI	NO	AI	NO	AI	
A	●	10		16		18		ø3.0~ø12.7mm
B	●	10	2	16	2	16		ø12.7~ø31.75mm
C	●	2		2		2		ø31.75~ø50.8mm
D	●	2		2		2	2	ø50.8~ø88.9mm

Parameters of HPE series CNC Turret Punch

Parameter	Unit	HPE-3044	HPE-3047	HPE-3048	HPE-3057	HPE-3058	HPE-3078
Normal pressure	KN	294	294	294	294	294	294
Max.processing sheet size (including one repositioning)	mm	1250×2500	1250×4000	1250×5000	1500×4000	1500×5000	2000×5000
Max.processing sheet thickness	Carbon steel	mm	6.35	6.35	6.35	6.35	6.35
	Stainless steel	mm	4	4	4	4	4
Max.punch diameter	mm	ø88.9	ø88.9	ø88.9	ø88.9	ø88.9	ø88.9
Punch accuracy	mm	±0.1	±0.1	±0.1	±0.1	±0.1	±0.1
Ram stroke rates	cpm	2300	2300	2300	2300	2300	2300
Punch frequency (1mm step, 6mm punching stroke)	cpm	750	750	750	750	750	750
Punch frequency (25.4mm step, 6mm punching stroke)	cpm	400	410	410	410	410	410
Maximum speed of the plate movement	m/min	102	102	102	102	102	102
Turret speed	rpm	30	30	30	30	30	30
CNC axis		5 (X,Y,T,C,Z)	5 (X,Y,T,C,Z)	5 (X,Y,T,C,Z)	5 (X,Y,T,C,Z)	5 (X,Y,T,C,Z)	5 (X,Y,T,C,Z)
Total power consumption	kW	6.1	6.1	6.1	6.1	6.1	6.1
Air resource	Mpa	0.6	0.6	0.6	0.6	0.6	0.6
Overall dimension	L	mm	5610	5610	5610	6110	6110
	W	mm	2300	4000	5000	4000	5000
	H	mm	2260	2260	2260	2260	2450
Weight	kg	14000	15000	16000	18000	19000	25500

HPC Series

CNC Turret Punch



- Main axis are controlled by servo punching system, stable and reliable.
- Full touch man-machine interface, powerful CNC system
- Constant meshing rotary station from patented technology, gains higher repeat precision
- New industrial design, more pleasing
- Highly efficient precision rolling forming
- Energy saving, low energy consumption, low noise

HPC Series CNC Turret Punch

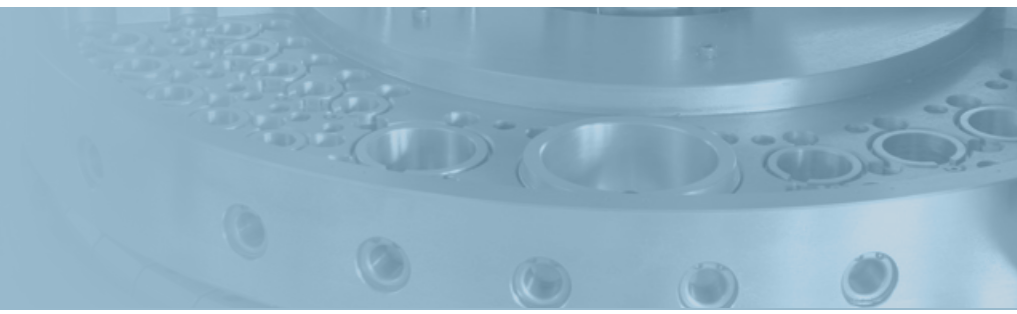

Touch Human-machine Interface

- Adopting 17-inch touch human-machine interface, special designed for turret punch, easy operating and powerful function
- Integrated functions such as off-line simulation, dynamic simulation, tool comparison and so on

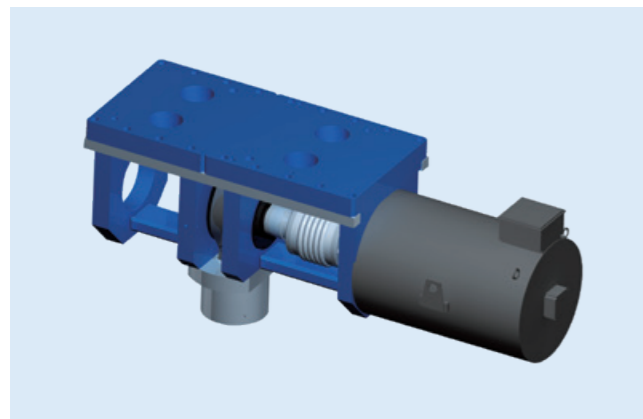

Servo Ram Design

- Main transmission uses servo motor coupled directly to crankshaft, mature and reliable. Full servo closed-loop control for precise positioning to any position within the stroke range for better punching performance



Turret Structure

- Turret processed through one-time clamp precision machining with high strength alloy casting steel, strong antioxidant and caring capacity, excellent vibration and precision-oriented performance, less tool stuck, strip or other phenomena, and effectively reduce the plate deformation when punching high-density holes
- Guide bushing with precision machining, significantly increasing the tool life

Standard Configuration

- Yawei CNC Controller
- Using punching system of full electrical servo control
- 38 Station turret with 2 auto-index station (2B station)
- Equipped with automatic lubrication for machine and sheet metal deformation sensors

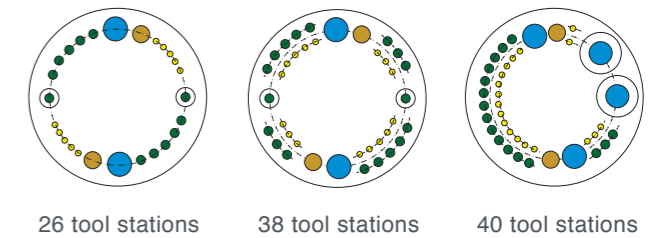

Tool station category	Symbol	26 tool stations		38 tool stations		40 tool stations		Dimension range
		NO	AI	NO	AI	NO	AI	
A	●	10		16		18		ø3.0~ø12.7mm
B	●	10	2	16	2	16		ø12.7~ø31.75mm
C	●	2		2		2		ø31.75~ø50.8mm
D	●	2		2		2	2	ø50.8~ø88.9mm

Parameters of HPC series CNC Turret Punch

Parameter	Unit	HPC-2544	HPC-2548	HPC-2558	HPC-2578	
Normal pressure	kN	245	245	245	245	
Max.processing sheet size (including one repositioning)	mm	1250×2500	1250×5000	1500×5000	2000×5000	
Max.processing sheet thickness	Carbon steel	mm	6.35	6.35	6.35	6.35
	Stainless steel	mm	4	4	4	4
Max.punch diameter	mm	ø88.9	ø88.9	ø88.9	ø88.9	
Standard tool station		38	38	38	38	
Punch accuracy	mm	±0.1	±0.1	±0.1	±0.1	
Ram stroke rates	cpm	1500	1500	1500	1500	
Punch frequency (1mm step, 6mm punching stroke)	cpm	620	620	620	620	
Punch frequency (25.4mm step, 6mm punching stroke)	cpm	350	350	350	350	
Maximum speed of the plate movement	m/min	102	102	102	102	
Turret speed	rpm	30	30	30	30	
CNC axis		5	5	5	5	
Air resource	Mpa	0.6	0.6	0.6	0.6	
Total power consumption	kW	6.1	6.1	6.1	6.1	
Overall dimension	L	mm	5410	5410	5910	7000
	W	mm	2300	5000	5000	5000
	H	mm	2260	2260	2260	2260
Weight	kg	14000	16000	19000	24500	

HPI Series CNC Turret Punch



- Adopts Germany H+L hydraulic system, punch stroke rates up to 1000 hits/min
- Patented Nisshinbo technology for keeping-touch Auto-Index design, with higher positioning accuracy
- Multi turrets to choose, adopt to different customers request
- Sophisticated control technology, widely applied
- Efficient and stable operation, low failure rate
- Outstanding cost performance ratio

HPI Series CNC Turret Punch

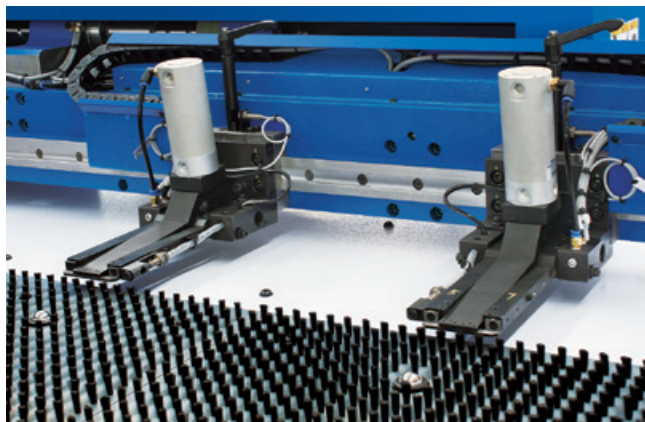

Turret Structure

- Turret processed through one-time clamp precision machining with high strength alloy casting steel, strong antioxidant and carrying capacity, excellent vibration absorption and precision-oriented performance, less tool stuck, strip or other phenomena, and effectively reduce the plate deformation when punching high-density holes
- Guide bushing by precision machining, significantly increases the tool life

Feeding Structure

- Long stroke double-precision grinding ball screw rod without using segmented compensation during control, smaller noise and resistance, longer life time
- Standard swing type pneumatic clamps, mature and stable, can be adapted to sheet deformation to ensure the long term stable operation

Hydraulic System

- Stroke rates up to 1000hits/min
- Compact design with high stability
- High cost performance with full forming function

Standard Configuration

- Siemens CNC Controller
- Hydraulic punching system from H&L Germany
- 38 station turret with 2 auto-index stations(2B station)
- Equipped with automatic lubrication for machine and sheet metal deformation sensors

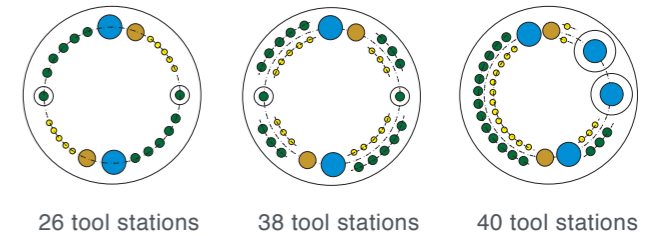

Tool station category	Symbol	26 tool stations		38 tool stations		40 tool stations		Dimension range
		NO	AI	NO	AI	NO	AI	
A	●	10		16		18		ø3.0~ø12.7mm
B	●	10	2	16	2	16		ø12.7~ø31.75mm
C	●	2		2		2		ø31.75~ø50.8mm
D	●	2		2		2	2	ø50.8~ø88.9mm

Parameters of HPI Series CNC Turret Punch

Parameter	Unit	HPI-3044	HPI-3047	HPI-3048	HPI-3057	HPI-3058
Normal pressure	kN	294	294	294	294	294
Max.processing sheet size (including one repositioning)	mm	1250×2500	1250×4000	1250×5000	1500×4000	1500×5000
Max.processing sheet thickness	Carbon steel	mm	6.35	6.35	6.35	6.35
	Stainless steel	mm	4	4	4	4
Max.punch diameter	mm	ø88.9	ø88.9	ø88.9	ø88.9	ø88.9
Standard tool station		38	38	38	38	38
Punch accuracy	mm	±0.1	±0.1	±0.1	±0.1	±0.1
Ram stroke rates	cpm	1000	1000	1000	1000	1000
Punch frequency (1mm step, 6mm punching stroke)	cpm	595	595	595	595	595
Punch frequency (25.4mm step, 6mm punching stroke)	cpm	295	295	295	295	295
Maximum speed of the plate movement	m/min	102	102	102	102	102
Turret speed	rpm	30	30	30	30	30
CNC axis		5 (X, Y, Z, T, C)	5 (X, Y, Z, T, C)	5 (X, Y, Z, T, C)	5 (X, Y, Z, T, C)	5 (X, Y, Z, T, C)
Total power consumption	kW	21	23	24	23	24
Air resource	Mpa	0.6	0.6	0.6	0.6	0.6
Overall dimension	L	mm	5600	5600	5600	6100
	W	mm	2300	4000	5000	4000
	H	mm	2200	2200	2200	2200
Weight	kg	14000	15000	16000	18000	19000

HPH Series CNC Turret Punch



- H+L hydraulic system, Punch frequency 600times/min
- Patented technology of keeping-touch auto index, positioning accuracy
- Multi turrets to choose, adapt to different customers request
- Sophisticated control technology, widely applied
- Efficient and stable operation, low failure rate
- Middle and high-end configuration, outstanding cost performance

HPH Series CNC Turret Punch

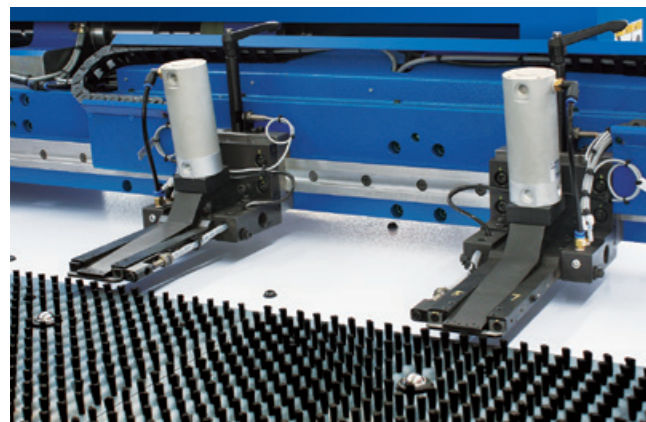

Turret Structure

- Turret processed through one-time clamp precision machining with high strength alloy casting steel, strong antioxidant and carrying capacity, excellent vibration absorption and precision-oriented performance, less tool stuck, strip or other phenomena, and effectively reduce the plate deformation when punching high-density holes
- Guide bushing by precision machining, significantly increases the tool life

Feeding Structure

- Long stroke double-precision grinding ball screw rod without using segmented compensation during control, higher positioning accuracy and axial load carrying capacity than single rod, smaller noise and resistance, longer life time
- Standard swing type pneumatic clamps, mature and stable, can be adapted to sheet deformation to ensure the long term stable operation

Hydraulic System

- Stroke rates of up to 600hits/min
- Compact design with high stability
- High performance punching with forming function

Standard Configuration

- Siemens CNC Controller
- Hydraulic punching system from H&L Germany
- 26 station turret with 2 auto-index stations(2B station)
- Equipped with automatic lubrication for machine and sheet metal deformation sensors

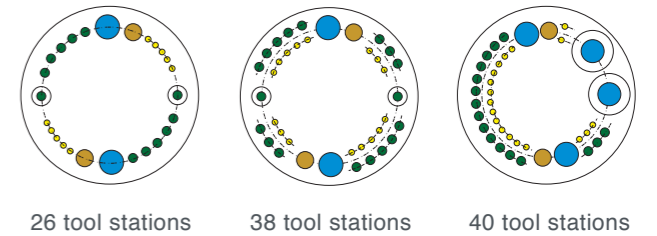

Tool station category	Symbol	26 tool stations		38 tool stations		40 tool stations		Dimension range
		NO	AI	NO	AI	NO	AI	
A	●	10		16		18		ø3.0~ø12.7mm
B	●	10	2	16	2	16		ø12.7~ø31.75mm
C	●	2		2		2		ø31.75~ø50.8mm
D	●	2		2		2	2	ø50.8~ø88.9mm

Parameters of HPH Series CNC Turret Punch

Parameter	Unit	HPH-3044/5044	HPH-3047/5047	HPH-3048/5048	HPH-3057/5057	HPH-3058/5058
Normal pressure	kN	300/500	300/500	300/500	300/500	300/500
Max.processing sheet size (including one repositioning)	mm	1250x2500	1250x4000	1250x5000	1500x4000	1500x5000
Max.processing sheet thickness	Carbon steel	mm	6.35/8	6.35/8	6.35/8	6.35/8
	Stainless steel	mm	4/6	4/6	4/6	4/6
Max.punch diameter	mm	ø88.9	ø88.9	ø88.9	ø88.9	ø88.9
Standard tool station		26	26	26	26	26
Punch accuracy	mm	±0.1	±0.1	±0.1	±0.1	±0.1
Ram stroke rates	cpm	600/800	600/800	600/800	600/800	600/800
Punch frequency (1mm step, 6mm punching stroke)	cpm	320/340	320/340	320/340	320/340	320/340
Punch frequency (25.4mm step, 6mm punching stroke)	cpm	230/240	230/240	230/240	230/240	230/240
Maximum speed of the plate movement	m/min	102	102	102	102	102
Turret speed	rpm	30	30	30	30	30
CNC axis		4 (X, Y, T, C)	4 (X, Y, T, C)	4 (X, Y, T, C)	4 (X, Y, T, C)	4 (X, Y, T, C)
Total power consumption	kW	21	23	24	23	24
Air resource	Mpa	0.6	0.6	0.6	0.6	0.6
Overall dimension	L	mm	5600/5800	5600/5800	5600/5800	6100/6300
	W	mm	2300	4000	5000	4000
	H	mm	2200/2300	2200/2300	2200/2300	2200/2300
Weight	kg	14000/21000	15000/22000	16000/22500	18000/24500	19000/25500

Common Parts for Turret Punch

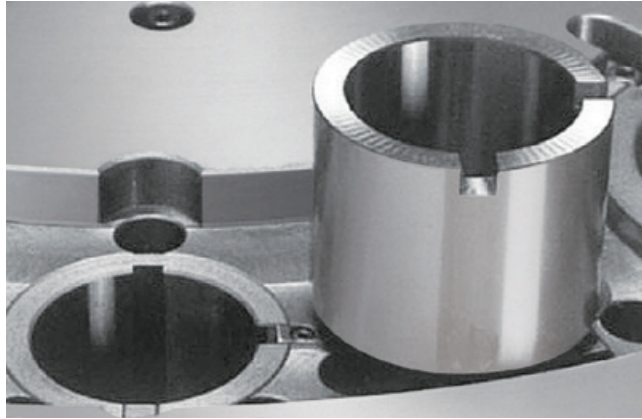

Hardened Tool Sleeve

- Turret adopts a sleeve structure, high guidance quality, the main body uses precise grinding after hardening, wear resistance, easy to replace



Long Guide Tool

- Long guide tool with high guidance for thick turret, precise servo positioning system suit a variety of complex high-quality forming tools, effectively absorb vibration during high-load punch to protect tools

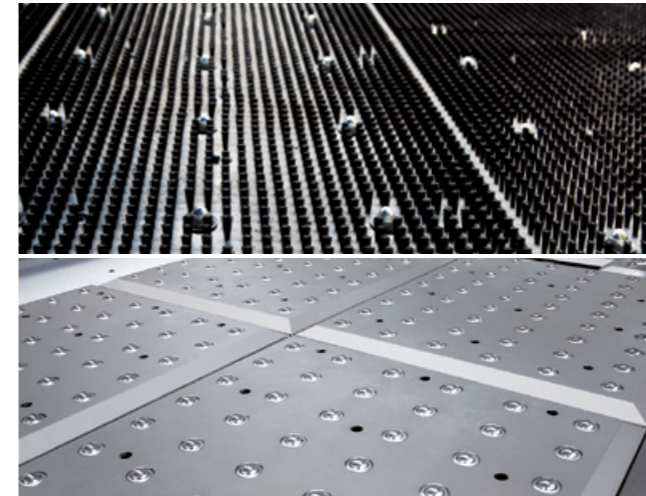
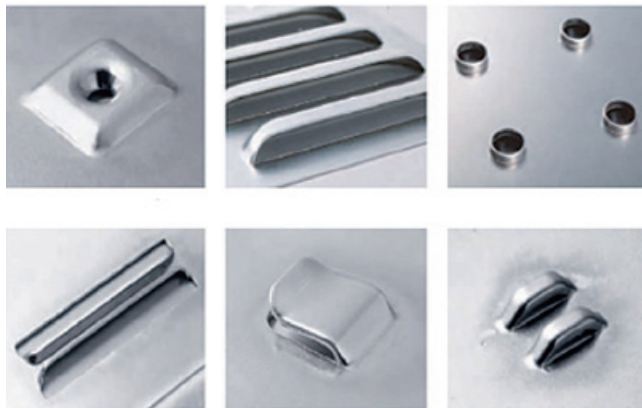

Standard Worktable

- Semi follow-up brush worktable structure, lower scratch and noise
- Recommended Use:
Thickness range 0.5~3.0mm—Brush worktable with steel balls
Thickness range 3.5mm~6.35mm—Stainless steel worktable



Automatic Lubrication

- Pressure switch alarm system reminds customer when system pressure insufficient
- Automatic oil level detection system to protect system when no lubrication oil



Sheet Deformation Detector

- When feeding sheet deformed, the detector switch will feedback to CNC system to stop and troubleshooting

Common Parts for Turret Punch



Electrical Cabinet Air Condition

- Effectively control high temperature and reduce dust invasion, extend the life of electrical components and ensure long-term stable operation

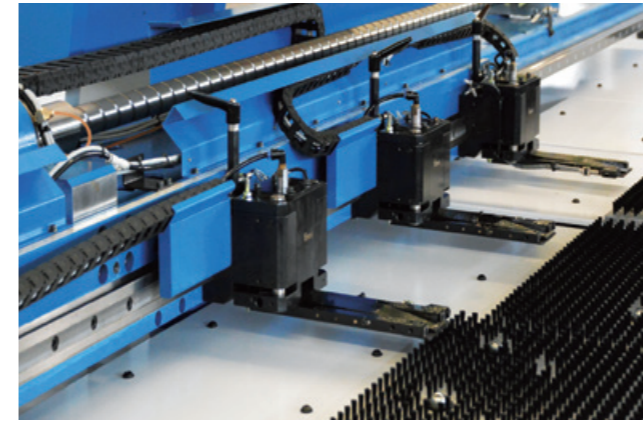

Complete Floating Clamp

- Float up and down along with the whole sheet, quickly adjust the clamp height for changes in working conditions
- Precise guide, high positioning accuracy

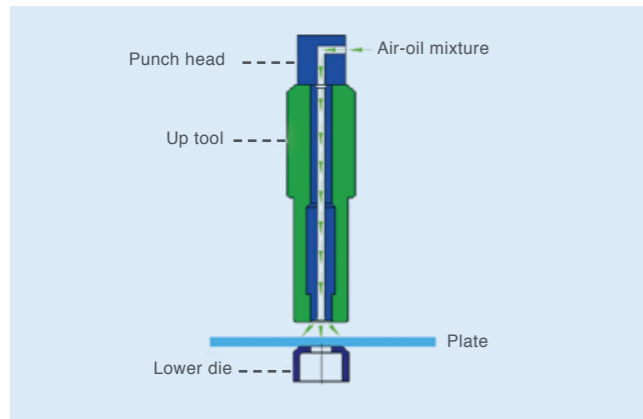

Oil Mist Protection Device

- Regularly lubricate the tool, the system determines whether it needs lubrication or not by reading the punch times, controls single lubricant amount through dedicated quantometer
- Low down the temperature of tool core through high pressure air blow, and increase tool working life

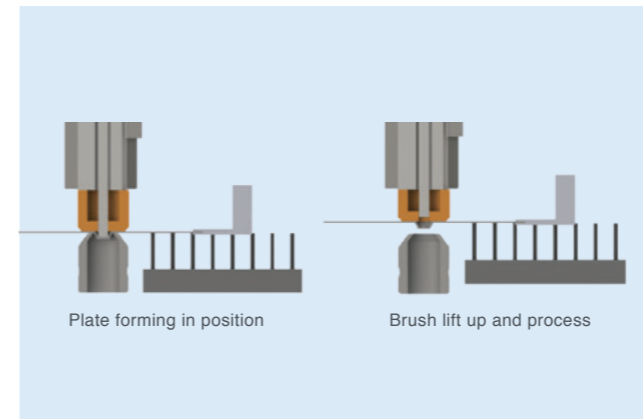

Down Forming Component

- After down forming, the worktable will lift up and position the sheet automatically when the workpiece moving
- Effectively reduce the rigid friction and guarantee sheet surface quality



Interactive Waste Collection Device

- Intelligent interactive use, improve work efficiency
- Two high-capacity waste buckets, reduce the frequency of cleaning scrap and labor intensity



Tool Hoisting Device

- The humanized design auxiliary tool hoisting device greatly reduces the job of manual operation, improves the safety and uncertainty, and can easily insert and pull out the upper tool weight more than 10kg

CNC Turret Punch Controller

CNC Turret Punch Programming Software

YAWEI CNC Controller System



Tool Library Management

- Graphical configuration of tools, easy to get information of tools
- When replacing tools in turret, mark different color in case of any mistake



Real-time Dynamic Simulation

- Display processing tool and sheet metal information in list, ready to edit the file and program
- Real-time dynamic simulation of the actual processing status, control the processing procedure vividly

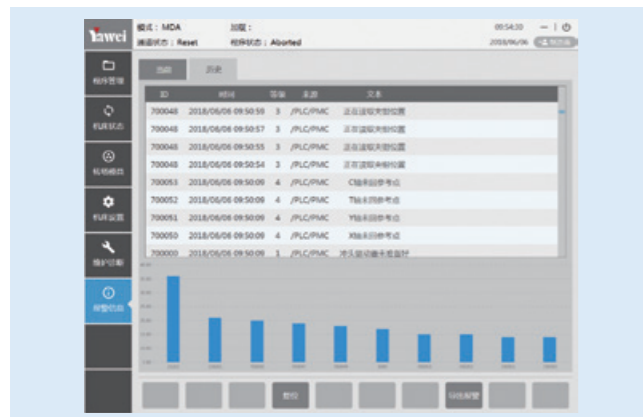

Parameter Management

- Export system configuration, parameter definition, alarm records, running logs at any time
- Import the external processing files easily

YAWEI Programming Software

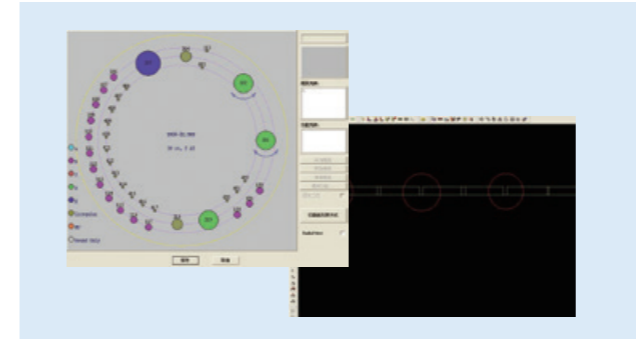

Feature

- The same interface for tool library and turret configuration
- Manual punch and micro-joint



Advantage

- One set software can be applied to different kinds CNC turret punch
- Convenient convert and import for multiple files



- Industrial Standard G code and M code

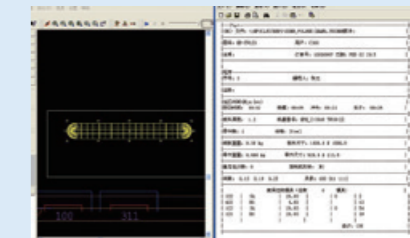

- Generate Report Automatically

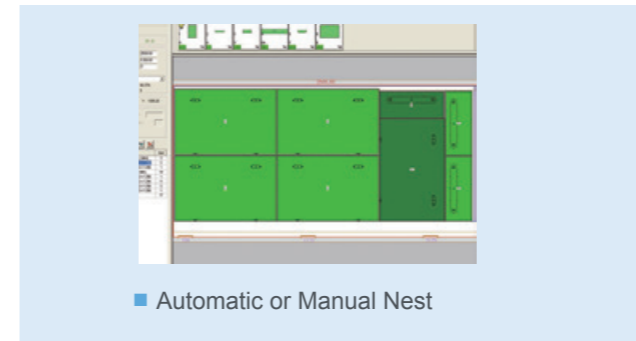

- Automatic or Manual Nest

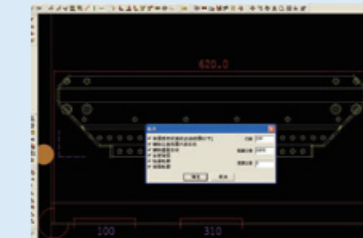

- Automatic Detection and Amendment

JIANGSU YAWEI MACHINE TOOL CO., LTD.

INTERNATIONAL

XIANCHENG INDUSTRIAL ZONE, HUANGHAI SOUTH ROAD

JIANGDU DIST. 225200 YANGZHOU, JIANGSU, CHINA

Sales hot line: +86-514-86880517 +86-514-86880518

Service phone: +86-514-86880517 +86-514-86880538

Part sales phone: +86-514-86880517

FAX: +86-514-86880521 +86-514-86882218

HTTP: www.yawei.cc

Email: sales2@yawei.cc



The above two marks both are commercial brand of Jiangsu Yawei Machine Tool Co., Ltd.
The contents are subject to change without prior notice

Service hot line: 400-000-2559



YAWEI WeChat



YAWEI Website